

Harley-Davidson Softail Rear Shock Lowering Kit 2018-2023

Mounting instructions



1. Check all clearances before, during and after installation.
2. Raise the rear of the motorcycle enough to take the weight off the shock. The rear tire must remain on the ground. Make sure motorcycle won't fall during all operations.
3. Remove seat, battery cover and frame crossmember. Take the rear shock off the bike following H-D factory service manuals.
4. Compress the spring using any special means you have in your shop (for example hydraulic press) and remove OEM shock head.
5. Replace the OEM shock head with the included new one. You can choose one of the four options using different included spacers combinations:

20 mm lowering, OEM fender
Use KC shock head (1)
and OEM nut (2)

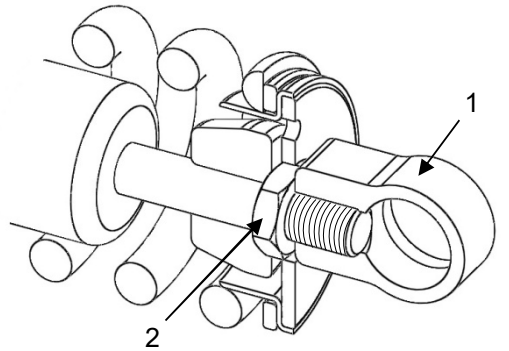

20 mm lowering, KC fender
Use KC shock head (1),
OEM nut (2) and two
8 mm spacers (3)
with fixing screws (4)

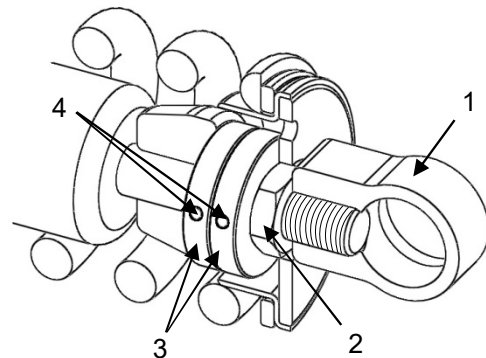

30 mm lowering, OEM fender
Use KC shock head (1) and 8 mm
spacer (2) with fixing screw (3).

Piston rod must be
shortened by 10 mm

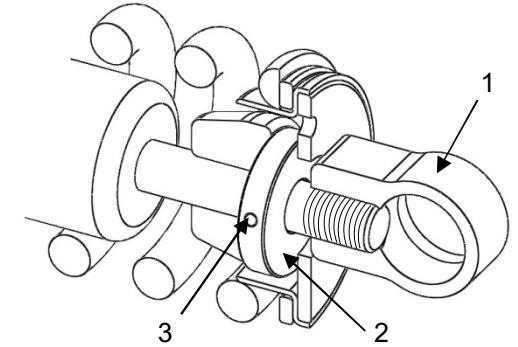
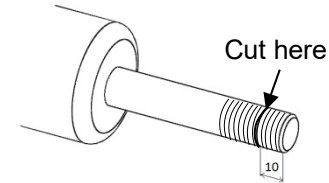

30 mm lowering, KC fender
Use KC shock head (1) and
19 mm spacer (2).

Piston rod must be
shortened by 10 mm

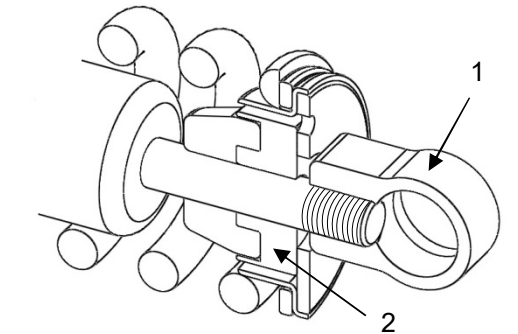
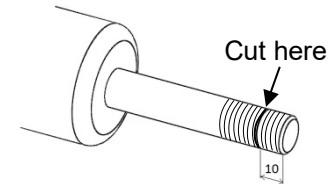

6. Use thread locker glue and tighten combination you have chosen. Carefully relive the spring.
7. Put the OEM grommet into the bearing of the new head. Put the shock absorber back to the motorcycle following the H-D factory service manuals.
8. Put frame crossmember, battery cover and seat back. Lower the motorcycle and the installation is complete.
9. After the installation make a test drive to be sure everything is working perfectly.

NOTE:

- Installation of this kit requires detailed knowledge of the motorcycle model and mechanics. It is assumed that the installer has access to the proper tools and a working knowledge of them and factory service manuals.
- When using this kit you must check all clearances. Overweight loads may cause the tire to hit inside of the fender.
- This kit is designed to be used with OEM shock absorbers.
- After the installation check the proper motorcycle parking lean angle. Special kickstand may be required.

Killer Custom assumes no responsibility or liability for damage or injury of any kind arising out of the use or misuse of any products.