

---

# Harley-Davidson V-Rod Lowering Kit 2" Inch



## Mounting instructions

---

1. Check all clearances before, during and after installation.
2. Raise the rear of the motorcycle enough to take the weight off the shocks. The rear tire must remain on the ground.
3. Loosen the top rear shock bolts without removing. Remove the bottom shock bolts.
4. Put the lowering bracket on the side of the shock as shown on the figure below. Apply the thread locker glue, put the original bolt and washer to the hole and tighten it.

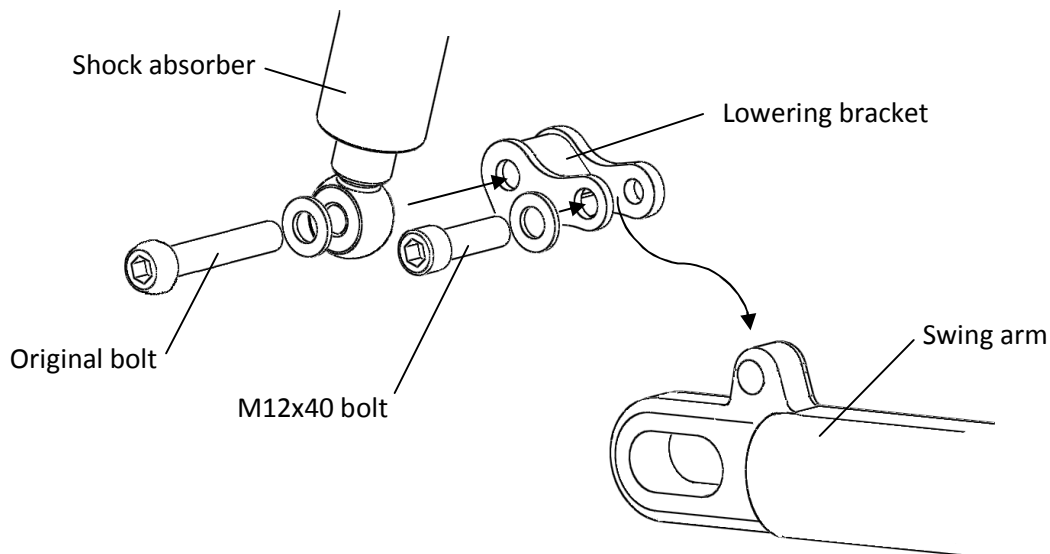

5. Note that on the left side of the motorcycle you have to remove the threaded bushing from the belt cover and put the belt cover lug inside the lowering bracket.
6. Holding the shock absorber slightly back, lower the rear of the motorcycle until the hole in the lowering bracket and shock absorber are aligned. Use thread locker glue and tighten this connection with included M12x40 bolt and washer.
7. Tighten the top shock bolts. Torque all bolts according to the factory service manual.
8. Put the included rubber dampers on the shock absorber rod.
9. Lower the motorcycle and the installation is complete.
10. After the installation make a test drive to be sure everything is working perfectly.

### NOTE:

- Installation of this kit requires detailed knowledge of the motorcycle model and mechanics. It is assumed that the installer has access to the proper tools and a working knowledge of them and factory service manuals.
- When using this kit you must check all clearances. Overweight loads may cause the tire to hit inside of the fender.
- After the installation check the proper motorcycle parking lean angle. Special kickstand may be required.

**Killer Custom assumes no responsibility or liability for damage or injury of any kind arising out of the use or misuse of any products.**