

Universal Air Ride Pressure Gauge Kit Mounting instructions

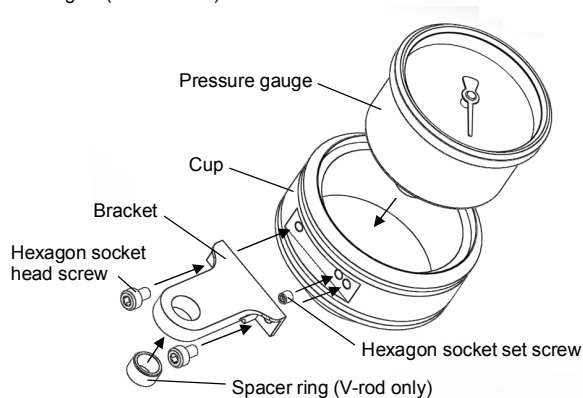

- ✓ Check all clearances before, during and after installation.
- ✓ You can choose different positions for mounting the Pressure Gauge on the rocker cover. Choose the one position that fits your motorcycle best, then fix the Gauge in the right position inside the Cup using the hexagon socket set screw.
- ✓ Attach the Bracket to the Cup using the Hexagon socket head screws and thread locker glue (not included).



- ✓ Unscrew the rocker cover screw and put the Pressure Gauge assembly in a selected position. Put the rocker cover screw back through the hole in the bracket and screw it according to H-D factory service manuals. For V-rod models, put the Spacer ring into the bracket hole before attaching the Pressure Gauge assembly to the rocker cover.
- ✓ Connect the air hose to the Air Pressure Gauge using the included L connector. Run the air pressure test. No air should be leaking in any connection. Make sure that air hose is protected from engine and exhaust system heat! Now the installation is complete.
- ✓ After the installation run a test drive to be sure everything is working perfectly.

NOTE:

- Installation of this kit requires detailed knowledge of the motorcycle model and mechanics. It is assumed that the installer has access to the proper tools and a working knowledge of them and factory service manuals.
- Some parts could be preassembled
- The Pressure Gauge is filled with glycerin to protect it's internals from the vibrations. The glycerin filling technology does not let to fill it full, so the visible air bubble is possible inside the Gauge.

Killer Custom assumes no responsibility or liability for damage or injury of any kind arising out of the use or misuse of any products.

Universal Air Ride Pressure Gauge Kit Mounting instructions



- ✓ Check all clearances before, during and after installation.
- ✓ You can choose different positions for mounting the Pressure Gauge on the rocker cover. Choose the one position that fits your motorcycle best, then fix the Gauge in the right position inside the Cup using the hexagon socket set screw.
- ✓ Attach the Bracket to the Cup using the Hexagon socket head screws and thread locker glue (not included).

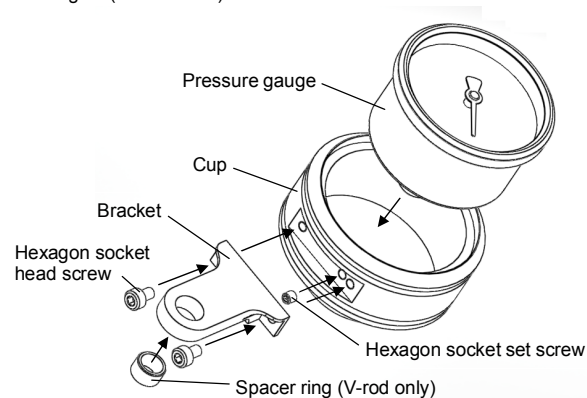

- ✓ Unscrew the rocker cover screw and put the Pressure Gauge assembly in a selected position. Put the rocker cover screw back through the hole in the bracket and screw it according to H-D factory service manuals. For V-rod models, put the Spacer ring into the bracket hole before attaching the Pressure Gauge assembly to the rocker cover.
- ✓ Connect the air hose to the Air Pressure Gauge using the included L connector. Run the air pressure test. No air should be leaking in any connection. Make sure that air hose is protected from engine and exhaust system heat! Now the installation is complete.
- ✓ After the installation run a test drive to be sure everything is working perfectly.

NOTE:

- Installation of this kit requires detailed knowledge of the motorcycle model and mechanics. It is assumed that the installer has access to the proper tools and a working knowledge of them and factory service manuals.
- Some parts could be preassembled
- The Pressure Gauge is filled with glycerin to protect it's internals from the vibrations. The glycerin filling technology does not let to fill it full, so the visible air bubble is possible inside the Gauge.

Killer Custom assumes no responsibility or liability for damage or injury of any kind arising out of the use or misuse of any products.